

THROTTLE CONTROL MOTOR KIT

Hopper Spreaders

INSTALLATION INSTRUCTIONS

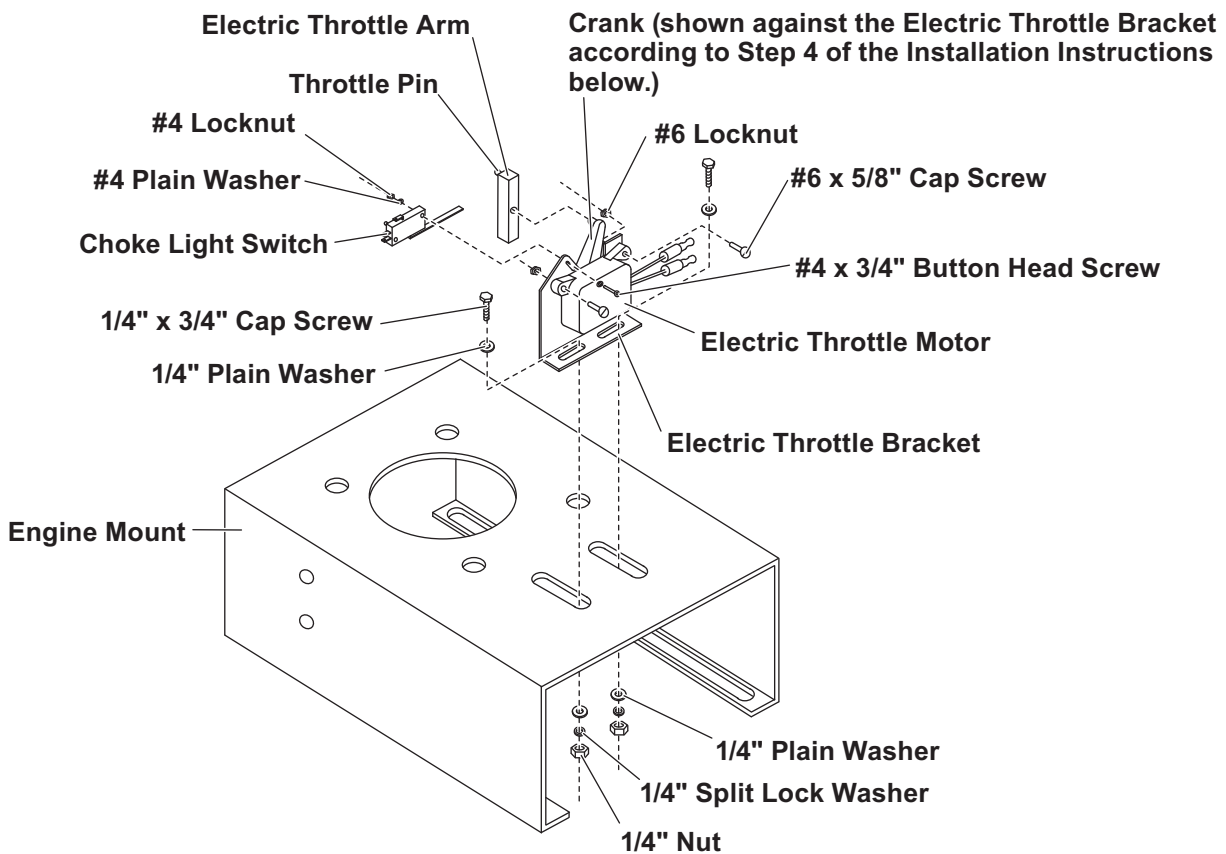

⚠ CAUTION

Use standard methods and practices when attaching spreader and installing accessories including proper personal protective safety equipment.

Removal Instructions

1. Disconnect the battery cables.
2. Carefully observe the existing installation. Mark the electric throttle position on the engine mount.
3. Disconnect the brown and red spreader harness wires from the electric throttle motor leads.
4. Remove the 1/4" fasteners that hold the electric throttle bracket to the engine mount.
5. Remove the #6 fasteners holding the electric throttle motor to the bracket and retain for reinstallation. Remove and retain the electric throttle motor, choke light switch and throttle retainer (Honda only).

Installation Instructions

⚠ CAUTION

Improper installation can result in damage to the engine choke/throttle linkage.

1. Connect the brown and red spreader harness wires (not shown) to the corresponding colored electric throttle motor leads.
2. Using the electric throttle control, run the new motor until the crank reaches the 1 o'clock position for Honda and Briggs & Stratton engines, or the 3 o'clock position for Tecumseh engines. (A 9-volt battery can be used as a substitute for the control.)
3. Choose the correct electric throttle bracket for the engine type. Fasten the choke light switch and throttle retainer (Honda only) using the existing hardware.

Honda

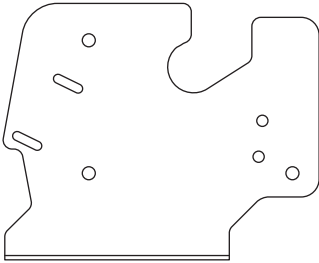

Briggs & Stratton

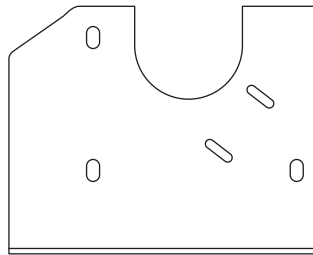

Tecumseh

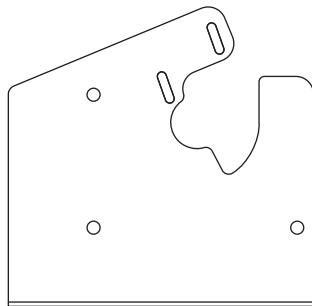

4. Fasten the electric throttle motor to the bracket using the existing hardware, adding two of the supplied washers between the motor and bracket at each mounting location.
5. Using the electric throttle control, run the new electric throttle motor until the crank is against the bracket as shown in above diagram.
6. Place the electric throttle arm on the crank as shown in the above diagram.
7. Place the electric throttle assembly onto the engine mount inserting the throttle pin into the engine choke/throttle linkage plastic slider (not shown).
8. Loosely bolt electric throttle assembly to the engine mount with the existing hardware.
9. Keeping the electric throttle arm parallel to and against the carburetor control bracket, move the electric throttle bracket forward putting the engine throttle into the full choke position.
10. Tighten the fasteners according to the Torque Chart.
11. Reconnect the battery cables.
12. Verify the crank is stopped in both directions by the bracket, not the carburetor linkage.

The company reserves the right under its product improvement policy to change construction or design details and furnish equipment when so altered without reference to illustrations or specifications used. This equipment manufacturer or the vehicle manufacturer may require or recommend optional equipment for spreaders. Do not exceed vehicle ratings with a spreader. The company offers a limited warranty for all spreaders and accessories. See separately printed page for this important information.

Printed in U.S.A.