

SPINNER MOTOR/BELT

Poly Hopper Spreaders

SPINNER MOTOR BELT TENSION ADJUSTMENT

1. Remove the chute from the hopper.
2. Remove the five bolts that hold the motor cover in place. Disconnect the wires and remove the cover.

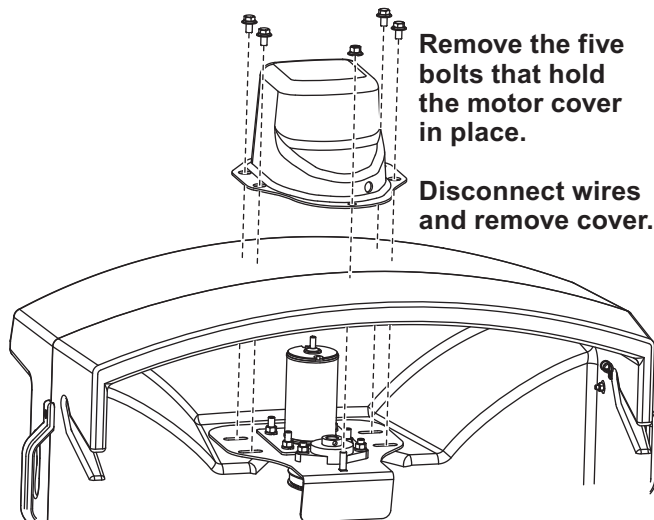

3. Replace two of the bolts on opposite corners of the motor to secure the base plate to the chute.

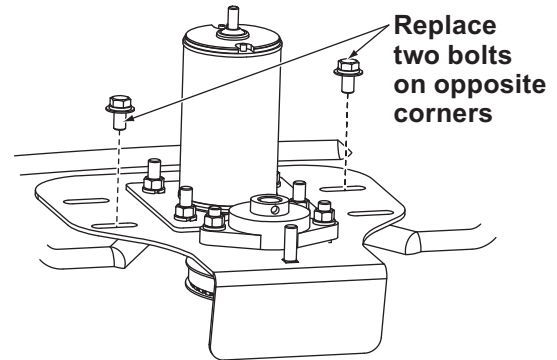

4. Loosen the four bolts that secure the motor mount plate to the base plate.

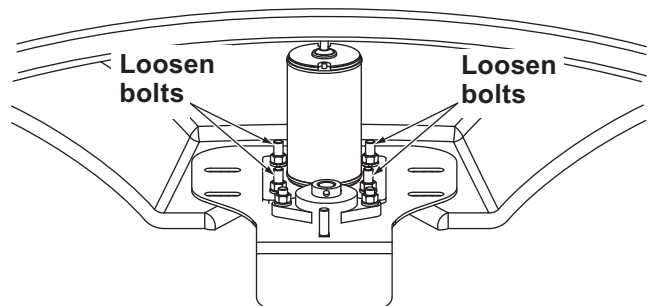

M1355, P3035, P3035K

- Slide the motor until the proper tension of the drive belt (when it is easily deflected 1/4") is achieved.
- Tighten the four motor mount plate bolts.
- Verify the belt tension. The belt should easily deflect 1/4" when it is properly tightened.
- Remove the two bolts holding the base plate to the chute and replace the cover.
- Tighten the five bolts to proper torque and reconnect the motor wires.
- Verify the belt tension. The belt should easily deflect 1/4" when it is properly tightened.

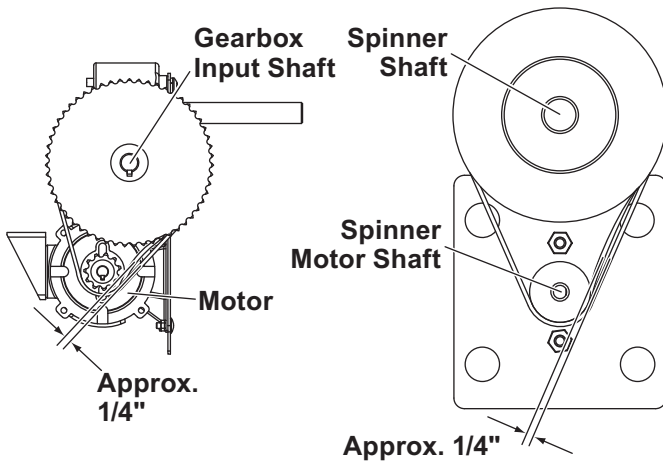

The company reserves the right under its product improvement policy to change construction or design details and furnish equipment when so altered without reference to illustrations or specifications used.

Printed in U.S.A.